

High temperature 36 mm crucible with flattened bottom

TS-36-A1

TS-36-A2

TS-36-A3

TS-36-Z1

CHARACTERISTICS

- operating temperatures up to 2200° C in both oxidizing and reducing atmospheres
- manufactured in high pressure Ceramic Injection Molding technology
- high accuracy of shape and dimensions
- very smooth surfaces
- available materials: alumina, yttria partially or fully stabilized zirconia, zirconia – alumina composite
- high mechanical strength
- dimensions Ø36 x 36 mm ±0,2%
- flattened bottom
- capacity 24,4 cm³
- weight 30,4 g

TYPICAL APPLICATIONS

- testing of chemical reactions
- high temperature roasting
- melting of metals
- melting of salts

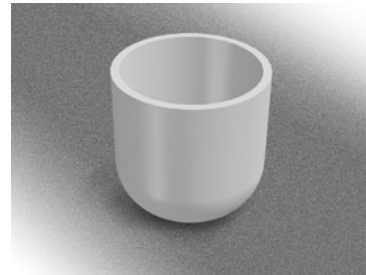

Crucible TS-36 can be used to heat treatment and chemical reacting of small amounts of substances. Flattened bottom enabled standing on flat surfaces. Manufacturing in high pressure Ceramic Injection Molding technology ensures keeping accuracy of shape and narrow dimensional tolerances.

Available materials:

- A1 - material Al₂O₃ 92% - operating temperature to 1400° C
- A2 - material Al₂O₃ 96% - operating temperature to 1500° C
- A3 - material Al₂O₃ 99% - operating temperature to 1600° C
- Z1 - material ZrO₂ 92% - operating temperature to 2200° C

Depending on customer's needs, this product is available in different dimensions.

High temperature 36 mm crucible with flattened bottom

TS-36-A1
TS-36-A2
TS-36-A3
TS-36-Z1

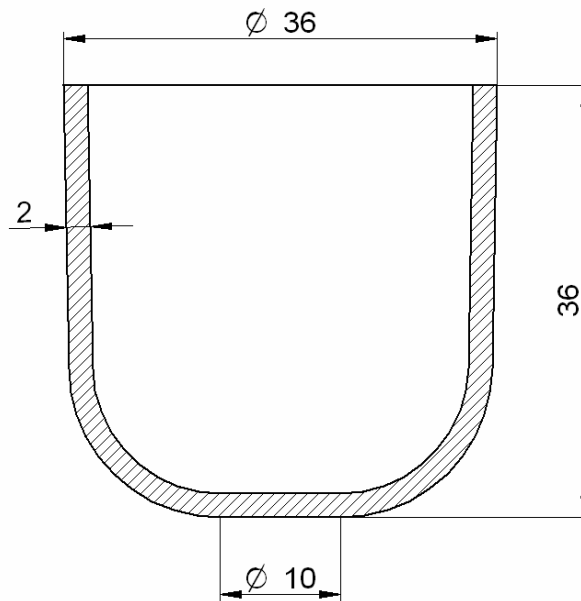

In a pack:
5 pcs.
20 pcs.
100 pcs.